



Product Data

A/SCS Series Split-Core Fixed Current "Status" Switches

Current



Product Description

The A/SCS and A/SCSX series current switches are available in a split-core with either Normally-Open (N/O) or Normally-Closed (N/C) output configurations. All of these sensors will have a solid-state output with a fixed trip point (setpoint). These current switches are ideal for providing status information on any type of AC current using equipment. Both the A/SCS and A/SCSX series current switches are an excellent choice for retrofit or existing installations, since you will not have to power down the unit and disconnect any wires during the installation process. The A/SCS and A/SCSX current switches are accurate, reliable, easy to install, and require less servicing than differential pressure switches, flow switches, and paddle wheels.

These current switches should be used in applications in which a "Go/No Go" current switch is required. The "Go/No Go" Current switches should be used to monitor the "on/off" status of any equipment that uses AC current.

The A/SCS and A/SCSX series current switches can be used to monitor devices with a maximum continuous operating current of up to 250 Amps depending on the model number ordered. These current switches will not need to be externally powered since the power for the switch is induced from the conductor being monitored. Another great feature of the A/SCS and A/SCSX series current switches is that they include a Red "Status" LED that will indicate whether the current is above the fixed trip point.

Product Specifications

Sensor Power	Induced from monitored conductor
Amperage Rating	See ordering info on back
Operating Frequency	40 to 1 kHz
Isolation Voltage	2,200 VAC
Max. Sensing Current Voltage	600 VAC
Output Switch Rating	A/SCS (N/O): 0.3A @ 200 VAC/VDC A/SCSX (N/C): 0.15A @ 300 VAC/VDC
Status LED Indication	Red LED - Above Trip Point
Aperture (Hole) Size	0.75", Accepts up to 350 MCM Cables
DIN Rail Size	35mm
Unit Weight	0.21 lbs
Operating Temperature Range	-15 to 40°C (5 to 104°F)
Operating Humidity Range	0 to 95% RH, non-condensing

Note: DO NOT use the LED's to indicate whether the sensors have power applied to them.

Wiring Diagrams available at www.workaci.com/instructions.htm
C0000002 Rev 10.pdf

Attributes:

- Split-Core design is suited for retrofit applications
- Integral Din-rail mounting flange
- Limited 5 year warranty
- UL94-5VB (enclosure rating)
- LED Indication
- Models rated to 200 and 250 amps

Applications:

- Monitoring fans, pumps and other electrical equipment for status
- Rated for industrial use

Automation Components, Inc.
2305 Pleasant View Rd.
Middleton, WI 53562
PH: (608) 831-2585
FAX: (608) 831-7407

DISPLAYS

TEMPERATURE

RELATIVE HUMIDITY

PRESSURE

CURRENT

AIR QUALITY

ACCESSORIES

Dimensions

Split-Core

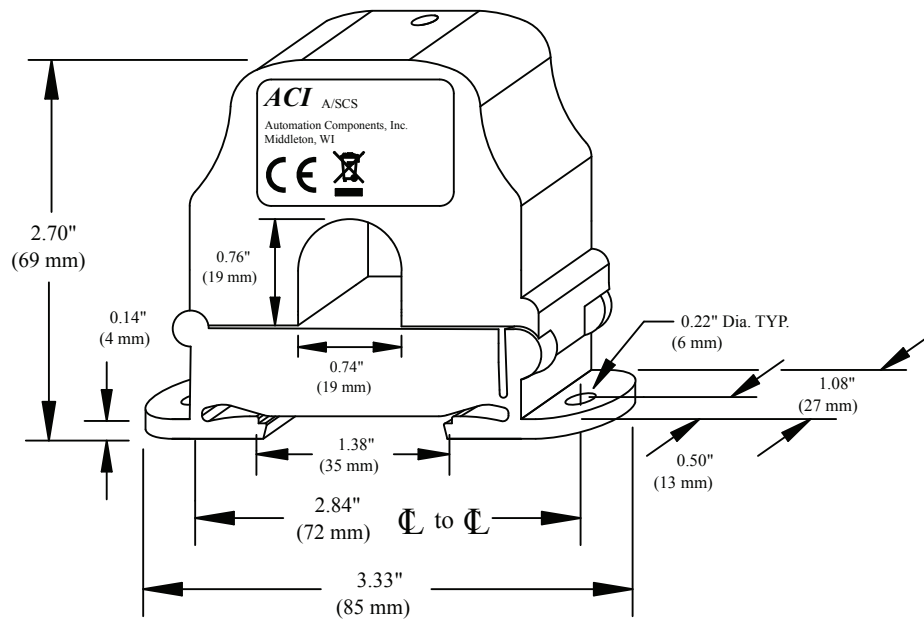

Ordering Information

ACI Model #	Description	Fixed Trip Point	Output Switch Rating
A/SCS	Split-Core Current Switch, N/O, 0-200A	2.50 Amps	0.30A @ 200 VAC/VDC
A/SCS-L	Split-Core Current Switch, N/O, 0-200A	1.50 Amps	0.30A @ 200 VAC/VDC
A/SCSX	Split-Core Current Switch, N/C, 0-250A	2.50 Amps	0.15A @ 300 VAC/VDC

Warning: Not intended to be used in Life & Safety Applications or for use in any hazardous locations.

DISPLAYS
TEMPERATURE
RELATIVE HUMIDITY
PRESSURE
CURRENT
AIR QUALITY
ACCESSORIES