

CS-PT1200 Series

Economical ceramic piezo-resistance pressure transmitter

Feature

±0.5, ±1%F.S Accuracy
 High Stability, High Reliability
 Ceramic Sensor from Germany
 Digital Calibration
 Multiple connectors and ports
 Zero point can be shifted freely
 Measure range shifted 50~100%
 CE approved
 RoHS approved

Application

Compressor
 Building Water Supply
 Hydraulic Control
 Air conditioner
 Auto Engine
 Automatic Detecting System
 Hydraulic pressure station
 Refrigerator

Introduction

CS-PT1200 series of pressure transmitters feature high quality, high stability, small size, low weight, compact structure, low cost and mass production. The products are widely used to measure pressure of air compressors, auto engines, air conditioning equipment, etc.

Stainless steel housings are ideal for industrial environment. Pressure sensing elements are selected from well known international brands. Special circuits are adopted to adjust zero and full range conveniently. The products have been approved with CE, intrinsically safe, and explosion-proof certificates

Non-polar two-wire current and three-wire voltage output are provided.

Products are produced according to military standards of advanced design, perfect technology, scientific management, strict production and quality control and have been sold to over 50 countries.

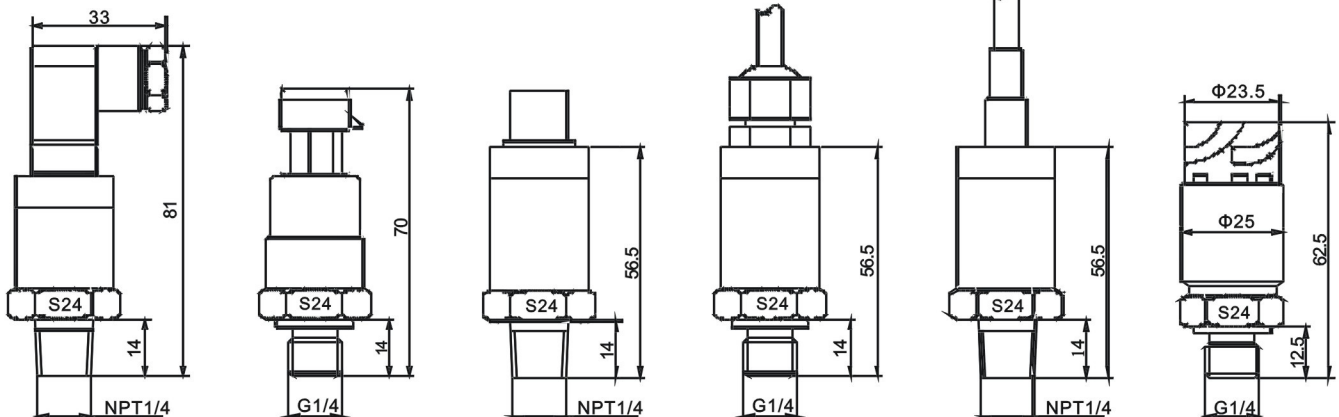

Technical Parameters

Parameter	Value		Note
Measure Range	2bar……600bar		1bar=100kPa
Overload Pressure	1.5×RP(rated pressure)		
Broken Pressure	3×RP(rated pressure)		
Accuracy	±0.5、±1%F.S		
Stability	Typical 0.5%F.S,Max 1%F.S		
Operating Temperature	-40℃~100℃		
Compensating Temperature	-10℃~80℃		
Storage Temperature	-50℃~125℃		
Medium Compatibility	Corrosive medium compatible with Cr18Ni9Ti、 ceramic		
Wires	Two-wire	Three-wire	
Output Signal	4~20mA	0.5~4.5V	
Power Supply	12~30Vdc	5Vdc/10~30Vdc/ac	dc/ac means dc and ac are both usable
Load Resistance	(U-10)/0.02(Ω)	>100KΩ	
Insulation	>100MΩ@50V		
Elec. connector	Packard, DIN 43650C, DIN72585, M12Seial, Cable		
Shell Protection	IP67		
Wire Protection	IP67		
Elec. Connect	G1/4, NPT1/4, 7/16-20UNF,		
Response Time	10ms		
Pressure Form	Gauge G , Absolute A		
Certificate	CE, Intrinsically safe E, Explosion-proof D		
EMC	EMI: EN50081-1/-2; EMS: EN50082-2		

Type Selection Guide

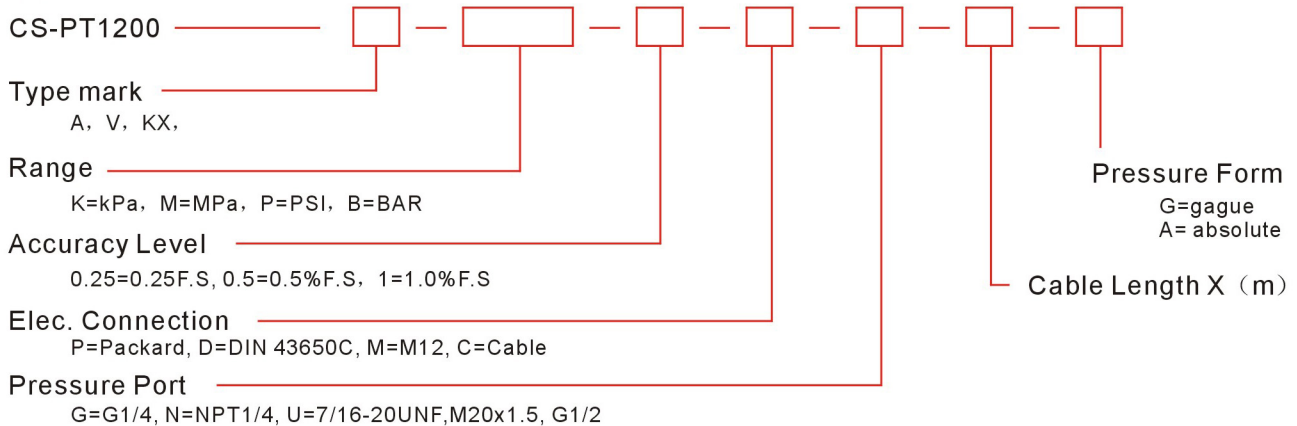

- CS-PT1200A—Voltage
- CS-PT1200V—Current
- CS-PT1200-KX—Especially for frequency water supply