



HL8102

Digital Temperature Controller

Floating / Modulating Control

FEATURES

- Digital display of sensing temperature and user selected temperature setting on demand
- Proportional plus integral (PI) advanced control with analog signal output
- Selectable 0-5Vdc, 1-5 Vdc, 0-10Vdc or 2-10 Vdc signal output
- Selectable direct / reverse acting output
- Output limited for over load protection
- Energy saving mode-external energy savings input (ESI) from card key or occupancy sensors
- Adjustable unoccupied setpoint for heating and cooling mode control
- Sleep mode control
- Model available for build-in or remote sensor (RS) function
- Remote control (RC) output for interlocking on / off control application
- Non-volatile memory (EEPROM) retains user settings during power loss
- Large LCD display with blue backlight
- °C or °F display unit
- Adjustable maximum and minimum setpoint limits
- Adjustable deadband (some dual outputs model)
- Control off output when system switch at "OFF" position
- RS-485 network interface
- Modbus RTU protocol.

GENERAL

The HL8100 series digital temperature controller is a microprocessor-based controller with digital LCD display.

The controller provided the floating control for damper actuator to adjust air volume in pressure-dependent variable air volume (VAV) box. Models are available for floating cooling control for damper actuator to adjust air volume, and modulating control for heating device to reheat temperature.

The controller provided proportional plus integral (PI) control with modulating and floating control output.

Application:

- Temperature control for variable air volume (VAV) box
- Temperature control for VAV with reheat box
- Modulating / Floating valve
- Modulating / Floating damper
- Constant temperature control

Technical data:

Supply Voltage:	24 Vac (±15%), 50/60 Hz
Setpoint Range: :	0 to 50.0 °C (programmable)
Display Range:	0 to 50.0 °C (programmable)
Display:	LCD display
Display Resolution:	0.1 °C
Setting Unit:	0.5 °C / step
Indication Accuracy:	± 0.5 °C over full range
Electrical Rating:	2 A run, 12 A inrush up to 250 Vac
Dimension:	86x86x23mm (H x W x D)

Order Guide:

Model	Output signal		Fan (Single/ 3-speed)	RS485 Network	Remote Control	Remote Sensor
	Floating	Modulating				
HL8102A	Cooling/Heating				√	√
HL8102AN	Cooling/Heating			√	√	√
HL8102B		Cooling/Heating			√	√
HL8102BN		Cooling/Heating		√	√	√
HL8102C	Cooling/Heating		√		√	√
HL8102CN	Cooling/Heating		√	√	√	√
HL8102D		Cooling/Heating	√		√	√
HL8102DN		Cooling/Heating	√	√	√	√
HL8102E	Cooling	Heating	√		√	√
HL8102EN	Cooling	Heating	√	√	√	√
HL8102F	Heating	Cooling	√		√	√
HL8102FN	Heating	Cooling	√	√	√	√
HL8102I	Cooling & Heating		√		√	√
HL8102IN	Cooling & Heating		√	√	√	√
HL8102K		Heating & Cooling	√		√	√
HL8102KN		Heating & Cooling	√	√	√	√

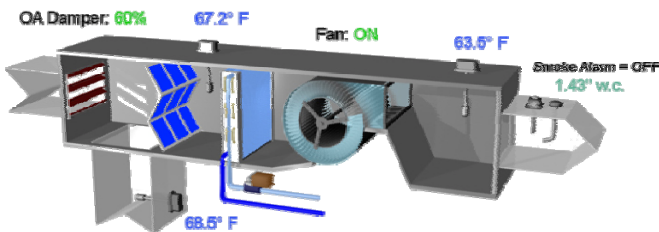

Typical wiring:

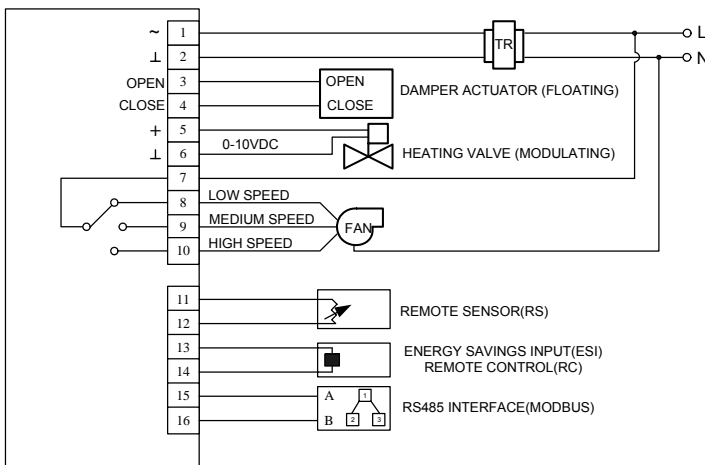

Control Performance:

- Proportional plus integral (PI) control

Output Signal for Cooling Control :

- Floating (SP3T), 0-5Vdc, 1-5 Vdc, 0-10Vdc, 2-10 Vdc

Output Signal for Heating Control :

- 0-5Vdc, 1-5Vdc, 0-10Vdc or 2-10Vdc

Maximum Output Load :

- 5 mA for 0-5Vdc, 1-5Vdc, 0-10Vdc or 2-10Vdc

Remote Control (RC) Output:

- SPST normally open (N.O.) dry contact output

Norms and standards:

Low voltage directive 73/23/EEC and 93/68/EEC

Product standard EN 60730